

# Mathematics

## Quarter 3 – Module 8: Perimeter

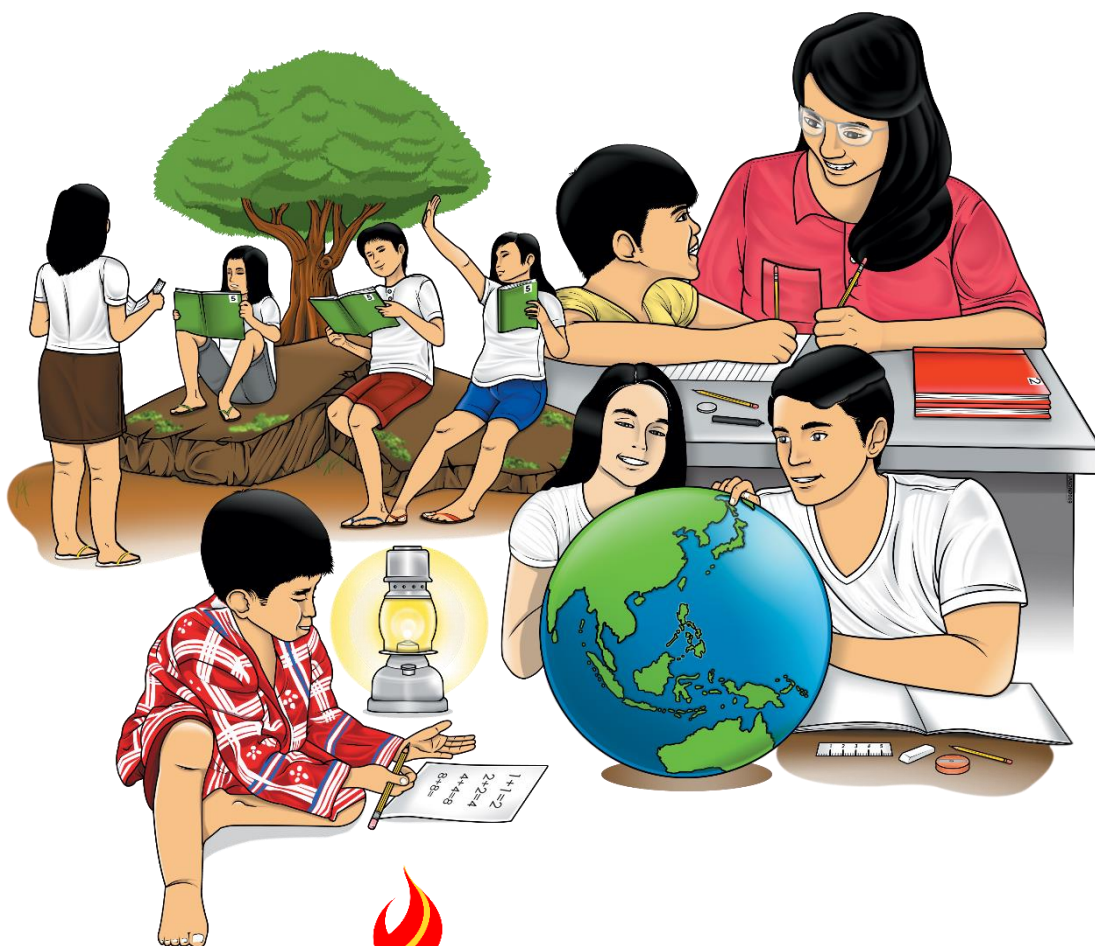

**Mathematics– Grade 4**  
**Alternative Delivery Mode**  
**Quarter 3 – Module 8: Perimeter**  
**First Edition, 2020**

**Republic Act 8293, section 176** states that: No copyright shall subsist in any work of the Government of the Philippines. However, prior approval of the government agency or office wherein the work is created shall be necessary for exploitation of such work for profit. Such agency or office may, among other things, impose as a condition the payment of royalties.

Borrowed materials (i.e., songs, stories, poems, pictures, photos, brand names, trademarks, etc.) included in this module are owned by their respective copyright holders. Every effort has been exerted to locate and seek permission to use these materials from their respective copyright owners. The publisher and authors do not represent nor claim ownership over them.

Published by the Department of Education  
Secretary: Leonor Magtolis Briones  
Undersecretary: Diosdado M. San Antonio

**Development Team of the Module**

<b>Writer:</b>	Michael L. Delgado
<b>Editor:</b>	Elena D. Hubilla
<b>Reviewers:</b>	Annabi M. Maravilla, Loyd H. Botor
<b>Illustrator:</b>	Michael L. Delgado
<b>Layout Artist:</b>	Cherry Lou O. Calison
<b>Management Team:</b>	Gilbert T. Sadsad, Francisco B. Bulalacao Jr., Grace U. Rabelas, Ma Leilani R. Lorico, Monserat D. Guemo, Florena M. Deuna

Printed in the Philippines by \_\_\_\_\_

**Department of Education – Region V**

Office Address : Regional Center Site, Rawis, Legazpi City, 4500  
Telefax : 0917-178-1288  
E-mail Address : region5@deped.gov.ph

4

# Mathematics

Quarter 3 – Module 8:  
Perimeter

## **Introductory Message**

This Self-Learning Module (SLM) is prepared so that you, our dear learners, can continue your studies and learn while at home. Activities, questions, directions, exercises, and discussions are carefully stated for you to understand each lesson.

Each SLM is composed of different parts. Each part shall guide you step-by-step as you discover and understand the lesson prepared for you.

Pre-tests are provided to measure your prior knowledge on lessons in each SLM. This will tell you if you need to proceed on completing this module or if you need to ask your facilitator or your teacher's assistance for better understanding of the lesson. At the end of each module, you need to answer the post-test to self-check your learning. Answer keys are provided for each activity and test. We trust that you will be honest in using these.

In addition to the material in the main text, Notes to the Teacher are also provided to our facilitators and parents for strategies and reminders on how they can best help you on your home-based learning.

Please use this module with care. Do not put unnecessary marks on any part of this SLM. Use a separate sheet of paper in answering the exercises and tests. And read the instructions carefully before performing each task.

If you have any questions in using this SLM or any difficulty in answering the tasks in this module, do not hesitate to consult your teacher or facilitator.

Thank you.



## ***What I Need to Know***

Have you experienced walking around outside your house? If you have done this, you already have walked the distance of the house's perimeter.

In this module, you will learn how to find the perimeter of a given figure. You can practically apply the things that you will learn from this module in your daily living.

After going through this module, you are expected to:

1. visualize the perimeter of any given plane figure in different situations;
2. measure the perimeter of any given figure using appropriate tools; and
3. find the perimeter of triangles, squares, rectangles, parallelograms, and trapezoids.



## What I Know

A. Study the figure carefully. Choose the letter of the correct formula/number sentence for finding the perimeter of each polygon.

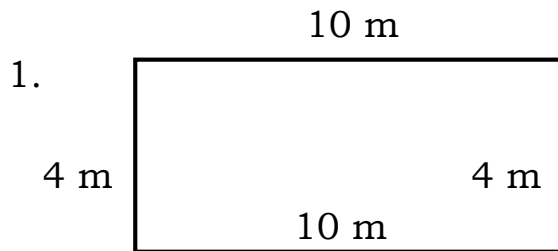

- a.  $10\text{ m} + 10\text{ m} + 10\text{ m} + 10\text{ m} = n$
- b.  $10\text{ m} + 10\text{ m} + 4\text{ m} + 4\text{ m} = n$
- c.  $10\text{ m} - 4\text{ m} + 10\text{ m} - 4\text{ m} = n$
- d.  $4\text{ m} + 4\text{ m} + 4\text{ m} + 4\text{ m} = n$

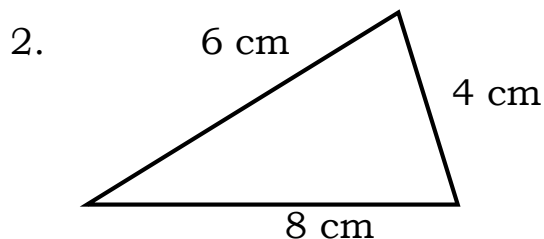

- a.  $8\text{ cm} \times 6\text{ cm} + 4\text{ cm} = n$
- b.  $8\text{ cm} - 6\text{ cm} + 4\text{ cm} = n$
- c.  $8\text{ cm} + 6\text{ cm} + 4\text{ cm} = n$
- d.  $8\text{ cm} - 6\text{ cm} \times 4\text{ cm} = n$

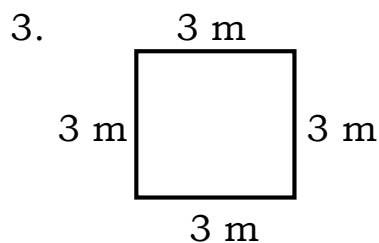

- a.  $3\text{ m} + 3\text{ m} + 3\text{ m} \times 3\text{ m} = n$
- b.  $3\text{ m} \times 3\text{ m} = n$
- c.  $4 \times 3\text{ m} = n$
- d.  $3\text{ m} \times 3\text{ m} \times 3\text{ m} - 3\text{ m} = n$

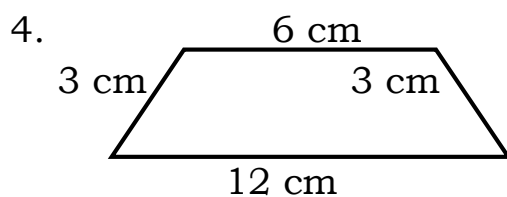

- a.  $3\text{ cm} + 3\text{ cm} + 6\text{ cm} + 12\text{ cm} = n$
- b.  $3\text{ cm} \times 3\text{ cm} + 6\text{ cm} + 12\text{ cm} = n$
- c.  $12\text{ cm} - 3\text{ cm} + 6\text{ cm} + 3\text{ cm} = n$
- d.  $3\text{ cm} + 3\text{ cm} + 6\text{ cm} - 12\text{ cm} = n$

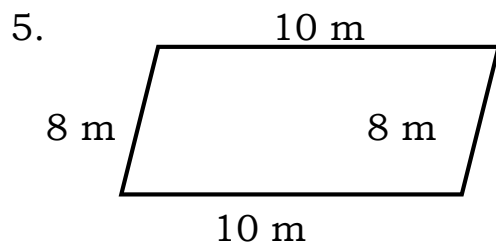

- a.  $10\text{ m} \times 8\text{ m} = n$
- b.  $10\text{ m} + 8\text{ m} = n$
- c.  $2 \times (10\text{ m} + 8\text{ m}) = n$
- d.  $8\text{ m} + 10\text{ m} - 8\text{ m} = n$

B. Find the perimeter of each figure.

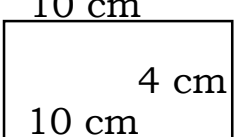
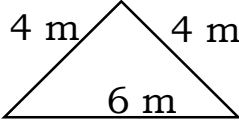
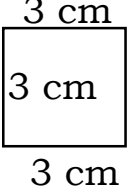
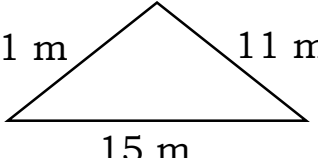
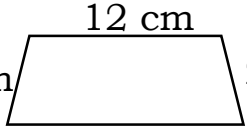
6. 
7. 
8. 
9. 
10. 

If you are done answering the activity, please go to the **Answer Key** on page 15 and check if your answers are correct. Thank you for your honesty in answering and checking your work. Hope you will do this until the end of this module.

## Lesson

# 1



# Perimeter



## *What's In*

Let us review first some of the concepts that can help you understand perimeter.

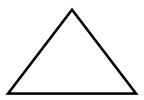
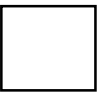
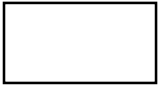
Examine closely the different polygons. Count the number of sides of each polygon and write the answer on the space provided.

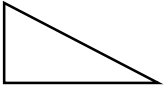
1.  \_\_\_\_\_
2.  \_\_\_\_\_
3.  \_\_\_\_\_
4.  \_\_\_\_\_
5.  \_\_\_\_\_

If you are done answering the activity, please go to the **Answer Key** on page 15 and check if your answers are correct. Thank you for your honesty in answering and checking your work. Hope you will do this until the end of this module.





## ***What's New***

Let us start learning the new concept with the help of this story problem.

Read the story problem.

Narlito is planning to build a fence around their house. The shape of their lot is rectangular with the sides of 12 meters, 10 meters, 12 meters and 10 meters. What is the total length of the fence he needs to build?

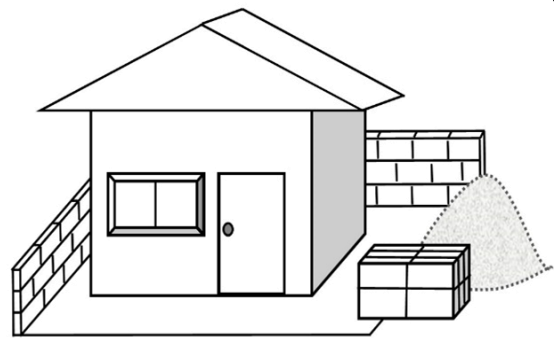

What is asked in the problem?

What are the given facts that can help you solve the problem?

What can you say about Narlito?

Try to answer the problem. Have patience and have fun!

We will find out on the next part of this module whether you answered the problem properly and correctly.



## What is It

To solve the given problem, we must find the distance around the lot of Narlito.

The distance around a closed plane figure is what we call **perimeter**. To determine the perimeter of the lot Narlito needs to fence, follow these steps:

1. Visualize Narlitos' lot.

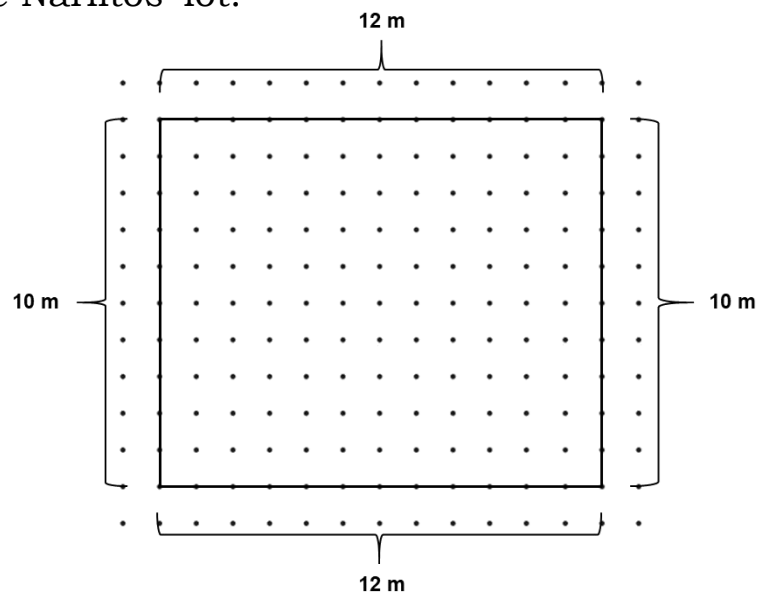

2. Derive the formula for the perimeter by adding the measure of each side of a given plane figure. Since the given figure has 4 sides, we say that **Perimeter = side + side + side + side**.  
**Then,  $P = s + s + s + s$**
3. Using the formula you developed, substitute the measurement of each side then add.

**So,**

$$\begin{aligned} P &= s + s + s + s \\ P &= 12 \text{ m} + 12 \text{ m} + 10 \text{ m} + 10 \text{ m} \\ \underline{P} &= \underline{44 \text{ m}} \end{aligned}$$

Therefore, the perimeter of Narlitos' lot is 44 meters.  
Thus, Narlito needs to fence 44 m.

Can you think of other ways to find the length of the fence he needs to build?

Let us try to visualize Narlitos' lot.

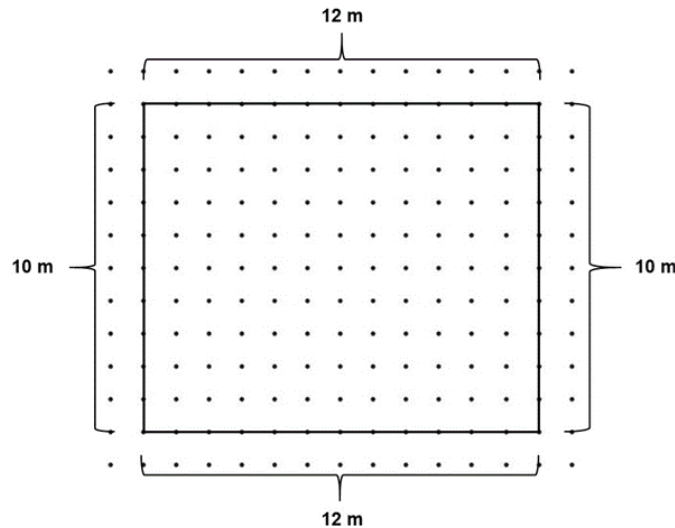

Let **L** be the length and **W** be the width of the rectangle.

Since the opposite parallel sides of a rectangle are equal in lengths, we say that Perimeter = 2 x L + 2 x W or Perimeter = 2 (Length + Width).

Then, Perimeter of a rectangle = 2 (L + W)

Using the formula you developed, substitute the measurement of each side then compute.

$$\begin{aligned} \text{So, } P &= 2 (L + W) \\ P &= 2 (12\text{m} + 10\text{m}) \\ P &= 2 (22\text{m}) \\ P &= 44 \text{ m} \end{aligned}$$

Therefore, the perimeter of Narlitos' lot is 44 meters.

Thus, Narlito needs to fence 44 m.

What if Narlito has a square lot? How do we solve its perimeter?

Let us try to solve for the perimeter of a square using this example.

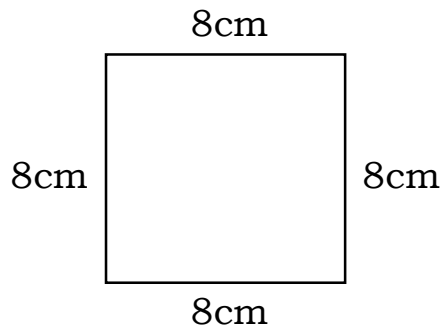

A square has 4 equal sides. We can find its perimeter by following these steps:

1. Aside from adding the 4 sides we can derive a formula for the perimeter of a square. Since the given figure has 4 equal sides, we say that Perimeter = 4 x side.

Then, Perimeter of a square = 4 x s

2. Using the formula you developed, substitute the measurement of each side then add.

So,

$$P = 4 \times s$$
$$P = 4 \times 8\text{cm}$$
$$P = 32\text{cm}$$

Therefore, the perimeter of the square is 32cm.

But what if you will be solving for the perimeter of a triangle? How do we solve for its perimeter?

Let us try to solve for the perimeter of a triangle using this example.

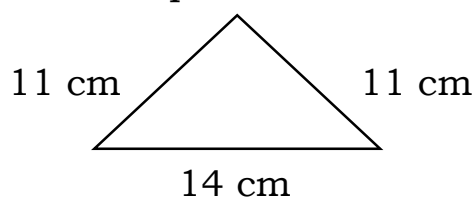

A triangle has 3 sides. We can find its perimeter by following these steps:

1. Derive the formula for the perimeter by adding the measure of each side of a given plane figure. Since the given figure has 3 sides, we say that **Perimeter = side + side + side** ( $P = s + s + s$ )

2. Add the measures of all its sides.

$$\text{So, } P = 11 \text{ cm} + 11 \text{ cm} + 14 \text{ cm}$$

$$P = 36 \text{ m}$$

Therefore, the perimeter of the given triangle is 36 cm.

You may follow the given steps in solving for the perimeter of other plane figures.

Just always remember that the **perimeter** is the total distance around a closed plane figure.

Let us now try measuring perimeter using an appropriate tool by performing the given task below.

Use an appropriate measuring tool to find the perimeter of the picture shown. Put the measurements in the box provided.

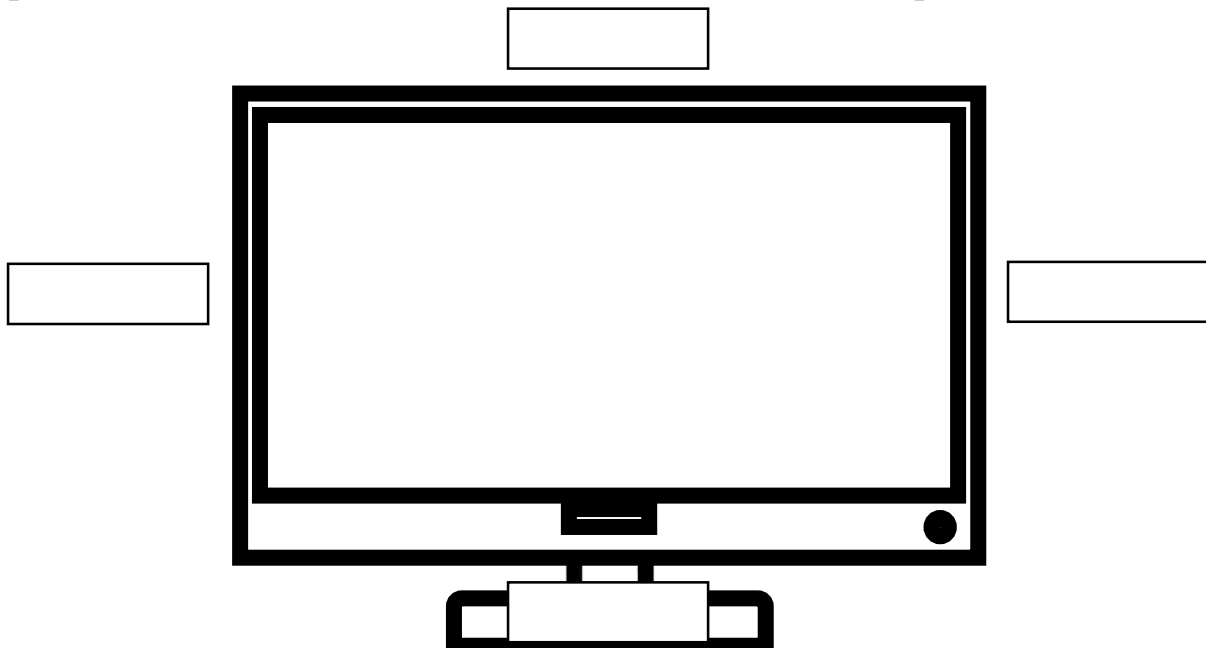

What are the measures of each side? What is the perimeter?  
What measuring tool did you use? Why?  
What unit did you use for the perimeter? Why?

Always remember that when measuring the perimeter of real objects, you need to use the appropriate tool and unit of length for the object.

- ✓ Inches and centimeters are used for smaller objects.
- ✓ Meters and feet are used for medium sized spaces and objects.
- ✓ Miles and kilometers are used for really long distances.

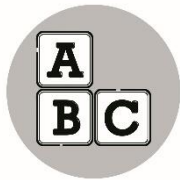

### *What's More*

Let us see if you already know how to find the perimeter of closed plane figures.

Find the perimeter of each figure.

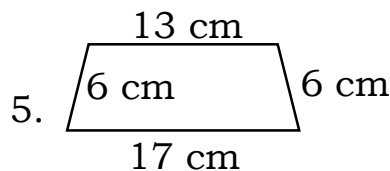
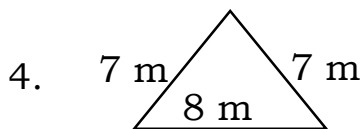
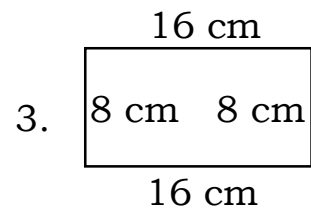
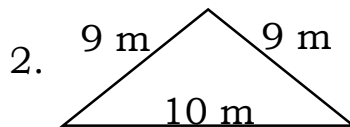
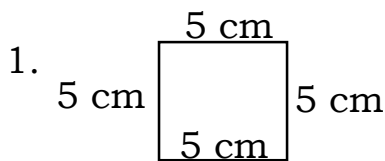

If you are done answering the activity, please go to the **Answer Key** on page 15 and check if your answers are correct. Thank you for your honesty in answering and checking your work. Hope you will do this until the end of this module.



## ***What I Have Learned***

You are doing great! Just always remember:

The perimeter of a closed figure is the distance around the figure.

To find the perimeter of a polygon:

- get the sum of the measurements of its sides.



## ***What I Can Do***

Let us see if you are now ready to solve this problem.

Read and understand the problem, then answer the questions that follow.

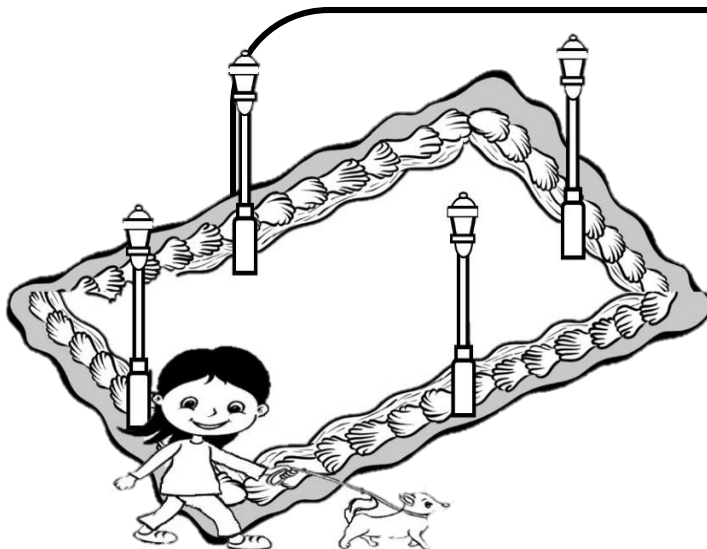

Annabelle, together with her dog walks around the rectangular park every day to stay fit. If the park has a length of 22 m and a width of 17 m, what is the distance that Annabelle walks?

What can you say about Annabelle?

What is asked in the problem?

What are the given facts that can help you solve the problem?

Solve for the distance that Annabelle walks. What is the answer?



## **Assessment**

You are now ready for the next activity.

A. Find the perimeter of each figure.

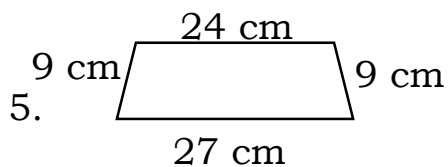
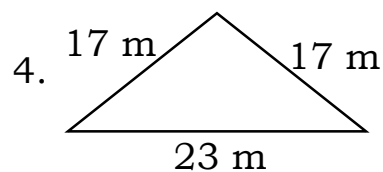
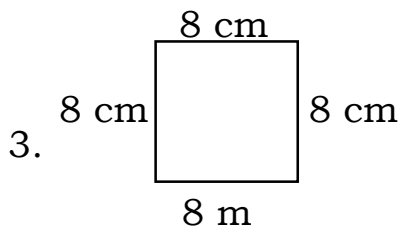
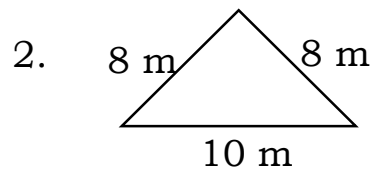
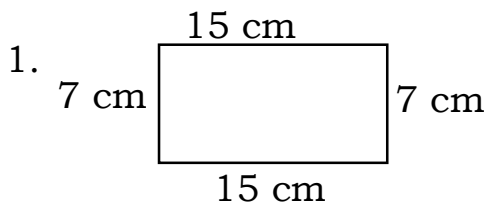



B. For numbers 6 and 7, follow the following steps:

- Use a ruler to measure the sides of each figure in centimeters.
- Write each length in the blank.
- Compute for the perimeter.

6.

\_\_\_\_\_ cm

\_\_\_\_\_ cm

\_\_\_\_\_ cm

\_\_\_\_\_ cm

**P = \_\_\_\_\_ cm**

7.

\_\_\_\_\_ cm

\_\_\_\_\_ cm

\_\_\_\_\_ cm

\_\_\_\_\_ cm

**P = \_\_\_\_\_ cm**

C. Complete the table.

Figure	Length	Width	Perimeter
8. A square garden	12 m		
9. A rectangular table	5 m	2 m	
10. Picture frame	16 cm	12 cm	

If you are done answering the activity, please go to the **Answer Key** on page 15 and check if your answers are correct. Thank you for your honesty in answering and checking your work. Congratulations!



## **Additional Activities**

Let us try some more.

A. Find the perimeter in meters.

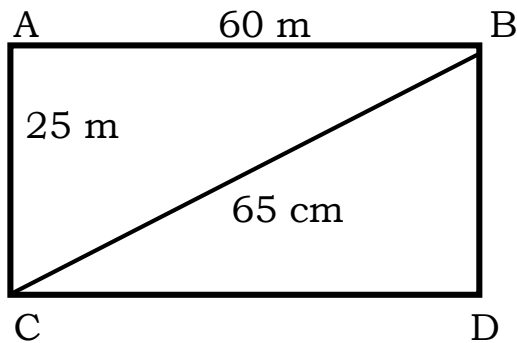

Rectangle ABCD = \_\_\_\_\_ m

Triangle ABC = \_\_\_\_\_ m

Triangle BCD = \_\_\_\_\_ m

C. Do what is asked.

1. Use a meterstick or a ruler to measure the perimeter of your table at home.
2. Use a ruler to measure the perimeter of one face of a box.

If you are done answering the activity, please go to the **Answer Key** on page 15 and check if your answers are correct. Thank you for your honesty in answering and checking your work. Congratulations!



# Answer Key

## Additional Activities (pages 13)

- A  
 1. Rectangle ABCD = 170 m  
 2. Triangle ABC = 150 m  
 3. Triangle BCD = 150 m  
 B  
 1. Answers may vary.  
 2. Answers may vary.

## Assessment

Figure	Length	Width	Perimeter
8. A square garden	12 m	12 m	48 m
9. A rectangle table	5 m	2 m	14 m
10. Picture frame	16 cm	12 cm	56 cm

## Assessment

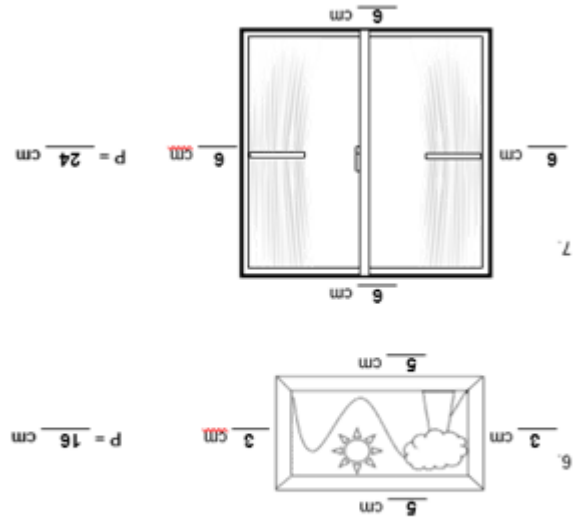

## What I Can Do

1. She is health conscious.
2. The distance that Annabelle walks
3. length of 22m and width of 17m
4.  $P = 78$  m

## What's More

1.  $P = 20$  cm
2.  $P = 28$  m
3.  $P = 48$  cm
4.  $P = 22$  m
5.  $P = 42$  cm

## Assessment

1.  $P = 44$  cm
2.  $P = 26$  m
3.  $P = 32$  cm
4.  $P = 57$  m
5.  $P = 69$  cm

## What I Know

- A  
 1. b  
 2. c  
 3. c  
 4. a  
 5. c  
 B  
 6.  $P = 28$  cm  
 7.  $P = 14$  m  
 8.  $P = 12$  cm  
 9.  $P = 37$  m  
 10.  $P = 30$  cm

## What's In

1. 3
2. 4
3. 4
4. 4
5. 3

## ***References***

K to 12 Mathematics Curriculum Guide, August 2016

Tabilang, Alma R. et al. *Mathematics 4 Learner's Material*.  
Department of Education. 2015.

Tabilang, Alma R. et al. *Mathematics 4 Teacher's Guide*.  
Department of Education. 2015.

**For inquiries or feedback, please write or call:**

Department of Education - Bureau of Learning Resources (DepEd-BLR)

Ground Floor, Bonifacio Bldg., DepEd Complex  
Meralco Avenue, Pasig City, Philippines 1600

Telefax: (632) 8634-1072; 8634-1054; 8631-4985

Email Address: [blr.lrqad@deped.gov.ph](mailto:blr.lrqad@deped.gov.ph) \* [blr.lrpd@deped.gov.ph](mailto:blr.lrpd@deped.gov.ph)